



8/275 Lyons Road

STYLISH STUDIO

Positioned on the 1st floor of 'Bayview', this bright modern security studio apartment offers a standout opportunity for first home buyers or investors. Superbly located on the border of Russell Lea and Five Dock, it's approximately 450m to both Lyons Road cafes and The Bay Run and only a 6km commute to the CBD. Neatly presented interiors, balcony and parking make this a great entry to a top location. • 1st floor setting in a well-maintained security block, manicured front garden. • ... for more information please visit our website

CAR	BATH	BED
1	1	1

SOLD

Sold \$320,000



Disclaimer: In preparing this brochure, Warwick Williams and it's related franchisees has relied in good faith upon information provided by others and has made all reasonable efforts to ensure that the information is correct. The accuracy of the information provided to you (whether written or verbal) cannot be guaranteed. If you are considering this property, you must make all enquiries necessary to satisfy yourself that all information is accurate.

Craig Davies 02 9719 8288

craigd@wwre.com.au

Morgan Davies-Forsyth 02 9719 8288

morgand@wwre.com.au

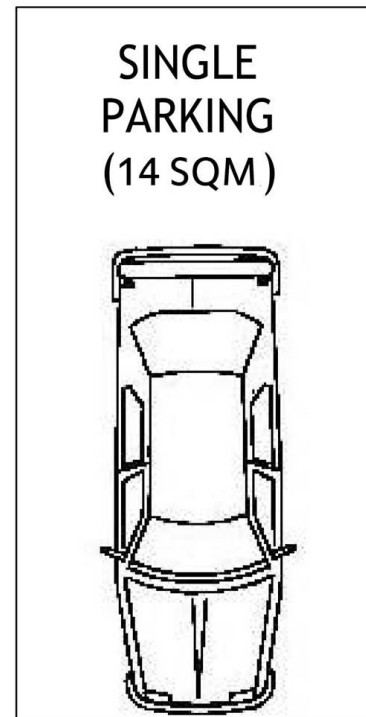

FIRST FLOOR

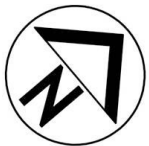

AREA: 22m² + Car Space (approximately)
WATER RATES: \$688.00 per Annum (approximately)
COUNCIL RATES: \$1,060.00 per Annum (approximately)
STRATA LEVIES: \$391.00 per Quarter (approximately)

8/275 LYONS ROAD, RUSSELL LEA

SCAPE Floor Planing Disclaimer: This floor plan is conceptual only. it is provided for illustrative purposes only and should not be relied upon. We make no guarantees to the correctness of this plan. All interested parties should make and rely on their own enquiries in determining the accuracy of the information contained in this floor plan.